

AOS Technology Ltd
14 Pate Road
Melton Mowbray
Leicestershire, LE13 0RG
United Kingdom
Tel: (44) 1664 567711
Fax: (44) 1664 567712
www.aosproducts.com

SPECIFICATIONS

Low DOP ASE Broadband Source

DL-ASE-CW-CSC183A

A. PRODUCT DESCRIPTION

The DenseLight DL-ASE-CW-CSXXXXA is a series Low DOP ASE broadband source for fiber optic gyroscope, fiber optic sensor, optical test instrument and optical coherence tomography. This DL-ASE-CW-CSXXXXA consists of a DenseLight standard ASE broadband source, a temperature controller and a built-in current driver capable for CW driving, which can be customized with various options to meet your specific needs. The broadband source covers over a wide wavelength range include O, E, S, C and L bands.

B. FEATURES

- Ex-fiber output power of >18dBm
- Spectral power density >-3.5dBm/nm over 1525 to 1565nm
- Low Degree of Polarization
- Single mode fiber output
- Integrated optical isolator
- Highly stable power output with active power control
- Built-in current driver and temperature controller
- Over temperature protection and internal PCB temperature monitor
- Single +5V power supply (optional power adapter)
- High wall-plug efficiency
- Compact size
- RoHS Compliance
- Telcordia Qualified broadband source (GR-468-CORE)

C. APPLICATIONS

- Optical Test Instrument
- Fiber Optic Sensors
- Fiber Optic Communications
- Optical Coherence Tomography
- Biomedical Imaging Device
- Clinical Healing Equipment

D. PHYSICAL DIMENSIONS AND MECHANICAL SPECIFICATION

Dimension:	L100 x W80 x H20 mm
Enclosure:	Metal Case
Optical output:	1 m SMF-28 fiber, 900um loose tube with FC/APC
Cooling:	Air-cooled or fan cooled. (Mounting holes for fan are provided)
Electronic interface:	10-way single row HE14 shrouded header

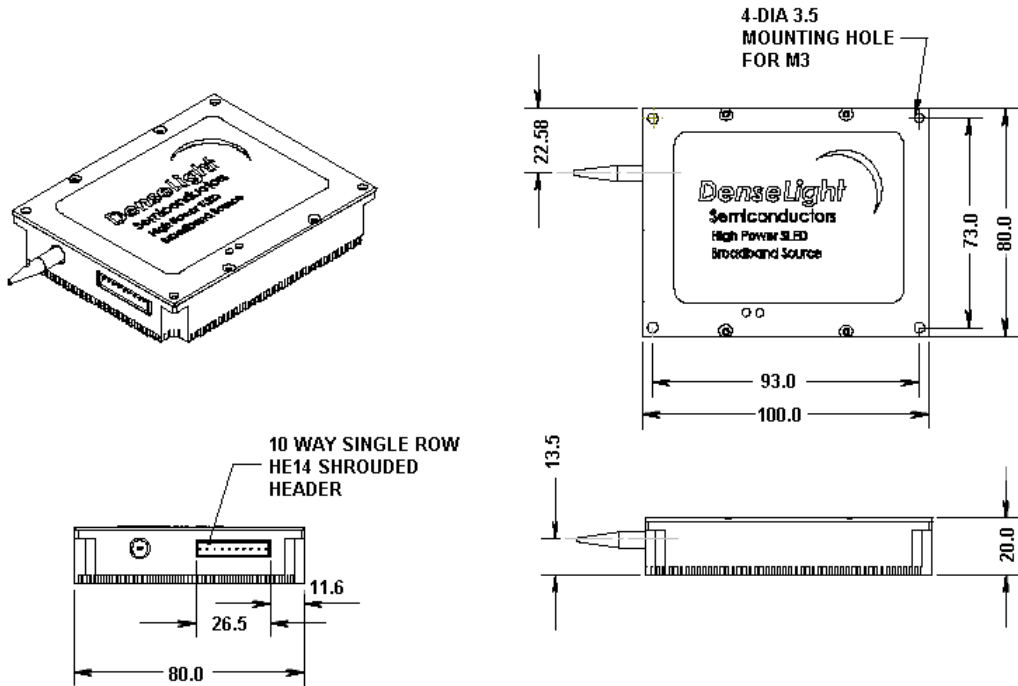

E. PIN ASSIGNMENT AND FUNCTION

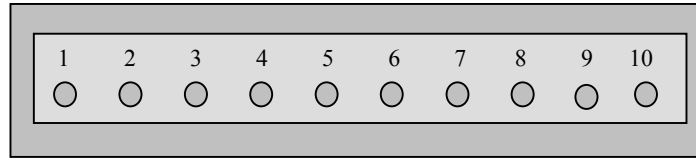

HE14 Shrouded Header Pin Layout (Pin 1 near to SMF output)

Pin Assignment

Pin No.	Symbol	Power/Control /Monitor	Analog /Digital	Input /Output	Description
1	P _{GND}	P			Power Supply Ground
2	P _{GND}	P			Power Supply Ground
3	V _S	P			+5V d.c.
4	V _S	P			+5V d.c.
5	OVRT	M	D	O	To report PCB over temperature and internal self-protection shutdown in operation (Active high)
6	T _{MON}	M	A	O	To monitor the temperature of PCB
7	P _{MON1}	M	A	O	To monitor the PD current in ASE1
8	P _{MON2}	M	A	O	To monitor the PD current in ASE2
9	LO_EN	C	D	I	To enable Light output (active low or no connection to enable light driver)
10	A _{GND}				Signal ground for control and monitor signals

F. ABSOLUTE MAXIMUM RATINGS

Parameter	Symbol	Condition	Min	Max	Unit
Operating temperature (Chassis) ¹	T _{op}	I _{op}	0	60	°C
Operating Relative Humidity ²	RH	I _{op}		85	%
Storage temperature	T _{stg}	Unbiased	-40	85	°C
Input current	I _s			6	A

¹) <0°C or >60°C extended range available

²) Non condensing

G. ELECTRICAL SPECIFICATIONS ³

Parameter	Symbol	Condition	Min	Typ	Max	Unit
Input Power Supply	V _s		4.75	5	5.5	V
Input Current	I _s				3	A
Total Power Consumption	P _s				15	W
Over Temperature	OVRT	Open-drain digital output with internal 1K pull-up to 3V for VH and 8mA current sink for VL				
	V _{OL}	Normal	0		0.45	V
	V _{OH}	Over-temp	2.0		3.0	V
Internal PCB Temperature Monitor	T _{MON}	Analog voltage: T _{MON} = 395mV + (6.2mV/°C x T), T = PCB temperature in °C				mV
Voltage	V _{OUT}	R _x = infinite	0		2.5	V
Output Impedance	R _{OUT}			150		Ω
Source Current	I _{OUT}	V _{OUT} = 2.5V			4	mA
Power Output Monitor	P _{MON1} P _{MON2}	Analog output: P _{MONx} ~ 1.5V x (P _o / P _{rated}), P _o and P _{rated} in mW				V
Voltage	V _{OUT}	R _x = infinite	0		3.0	V
Output Impedance	R _{OUT}			150		Ω
Source Current	I _{OUT}	V _{OUT} = 3.0V			4	mA
Light Output Enable	LO-EN	Digital input with internal 10K pull-down for light output enable at logic low or no connection				
	V _{IL}	Normal	0		1	Normal
	V _{IH}	Disable light output	2.5		3.3	Disable light output

³) Unless otherwise specified, tests are performed at T_{op} = 25°C.

H. OPTICAL SPECIFICATIONS

Parameter	Symbol	Min	Typ	Max	Unit
Power output	P_o	18			dBm
Power density @ 1525 to 1565nm	$P_{density}$	-3.5			dBm/nm
Bandwidth @ 3dB	B_{FWHM}	35			nm
Degree of polarization	DOP			5	%
Output stability ⁽⁴⁾ 1 hour	Stb			± 0.05	dB
8 hour				± 0.1	dB

⁴⁾ After 1 hour warm-up

I. TYPICAL OPTICAL PERFORMANCE

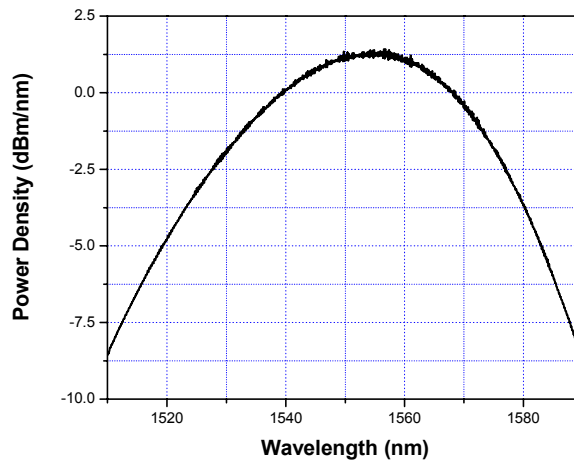

Spontaneous Emission Spectrum

J. APPLICATION INFORMATION

J.1 Typical Application Circuit

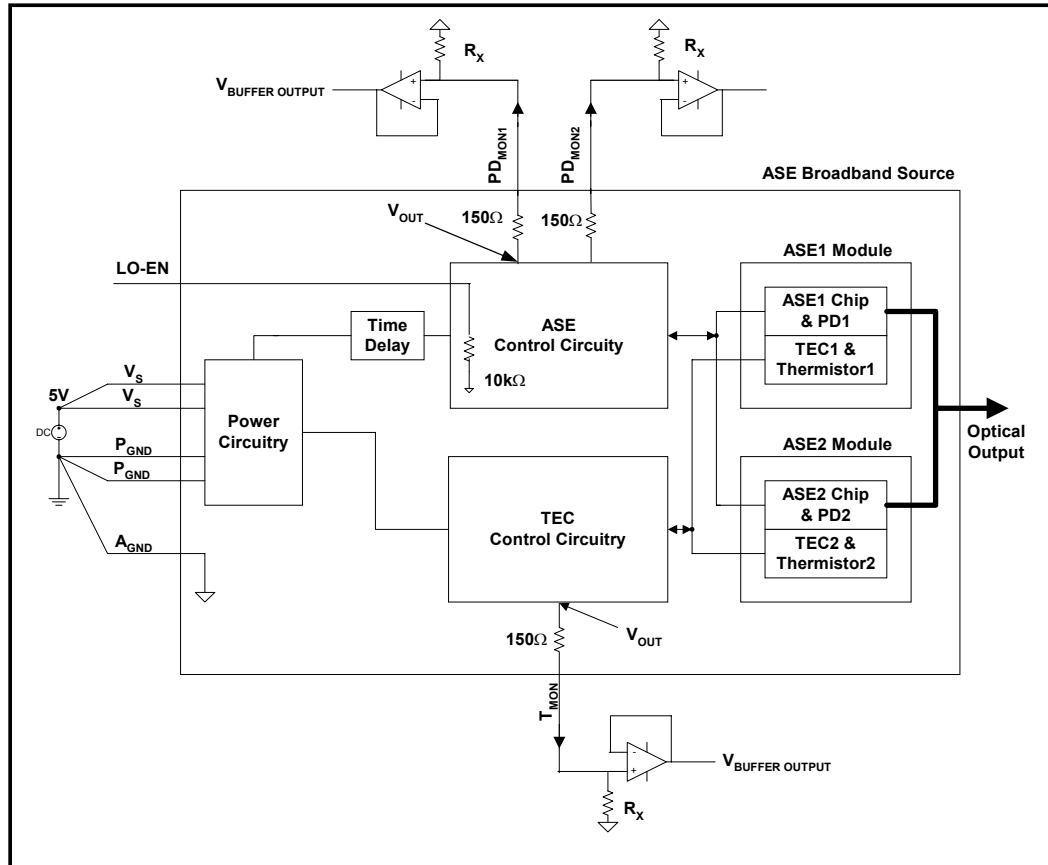

J.2 Power Supply Requirement and Connections

The power supply must be capable of supplying the maximum input current (I_s) as given in the electrical specification table at all times during operation. This is because during transients (eg. switching on the light source or with a sudden change in operating ambient temperature), the ASE broadband Source will require a momentary higher current from the power supply compared to its steady-state operation.

The two cables to the two V_s pins (Pin 3 and Pin 4) should be shorted at the positive terminal of the power supply as shown in the Typical Application Circuit. This is to divide the total current load to the broadband source between the two cables. Similarly, the two cables to the P_{GND} pins (Pin 1 and Pin 2), as well as the cable to the A_{GND} pin (Pin 10) should be shorted at the ground of the power supply terminal.

J.3 Selection of Resistance R_x for Analog Monitor Signals

In the Typical Application Circuit given, the function of R_x is to increase the current in the signal cables so as to reduce the effect of environmental noise on the analog monitor signals. In a noisy environment, the value of R_x is recommended to be $1k\Omega$. By choosing R_x to be $1k\Omega$, the actual voltage measured at the buffer output will be reduced due to loading effect, as compared to when R_x is infinite.

$$V_{\text{BUFFER OUTPUT}} = \frac{R_x}{R_x + 150} \times V_{\text{OUT}}$$

where R_x is resistance in Ω

In a non-noisy environment, the value of R_x can be increased to reduce loading effect. It is not recommended to choose R_x less than $1k\Omega$.

For further technical information, please refer to DenseLight Semiconductor Low DOP ASE Broadband Source User Operation Manual.

K. REVISION CONTROL

Authorized Personnel	Rev	Description of Change	Date
OTK	A	Initial: Production Release	28 February 2007

Manufacturer Information:

DenseLight Semiconductors PTE. LTD.
6 Changi North St. 2, S498831 SINGAPORE
www.denselight.com